

EPAS01 DATA SHEET

The EPAS01 Motorsport Assembly is designed for competition use only.



EPAS01

HOW IT WORKS

The EPAS01 motor/gearbox is designed to be inserted inline anywhere between the steering wheel and the steering rack. A built in torque sensor detects the amount of force applied by the driver and sends this information into the control ECU (ordered separately) which in turn determines the direction and amount of force the motor will deliver.

EPAS01 SPECIFICATION	
Operating Voltage	Nominal 13.8V DC
Maximum Current Draw	80 Amps
Average Current Draw	Circuit dependent
Weight:	5.35 Kg / 11.79 lbs
Maximum Torque Output	110 NM / 81 lb ft
No Load Rotation Speed(degrees /s)	800
Number Of Mounting Points	5
Spline Detail	9/16 - 36

BASIC DIMENSIONS

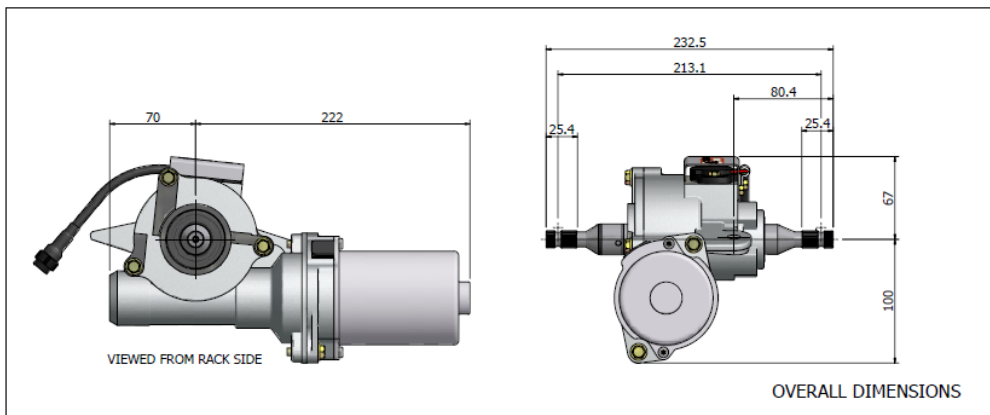

CONTROL ECU

Two types of control unit are available to operate with the EPAS01 Motor/Gearbox.



EPAS18 – Ultra ECU



EPAS35 – MIDI ECU

The EPAS18 ECU is designed for professional users and comes complete with Autosport connectors for interfacing with the wiring harness. The ECU casing is machined from billet and contains a high efficiency heatsink to help wick away unwanted thermal energy to ensure the system works at maximum effect.

The EPAS35 ECU contains the same circuitry and software as the EPAS18 but uses a commercial specification connector and cost effective enclosure that also omits the heatsink.

Both ECU's contain 5 user programmable steering maps and CAN bus connectivity to ensure all of the available steering parameters can be recorded on the vehicles data logger for future analysis.

Full specification of each ECU is available upon request.